

The shunt regulator DSR 50/5 is designed to limit the supply voltage of the amplifier. The threshold voltage can be selected as 27 V for up to 24 V supply voltage or as 56 V for up to 50 V supply voltage.

The shunt regulator DSR 50/5 is an article from the supplementary product line of maxon motor control.

Putting it into operation is very easy - additional equipment is not required.

In normal operation the value of the supply voltage is given by the power supply.

4-quadrant amplifiers are able to feed back brake energy into the supply and therefore work like a generator. Thus a long braking process can cause the supply voltage to rise due to the feed back energy. The task of the shunt regulator is to limit the voltage increase up to a permissible value and to transform the excess energy into heat.



### Table of contents

1	Safety Instructions .....	2
2	Performance Data .....	3
3	Minimum External Wiring .....	4
4	Operating Instructions .....	5
5	Operating Status .....	6
6	Diagram 1: Maximal performance depending on time .....	7
7	Diagram 2: Maximal power dissipation depending on temperature.....	7
8	Block Diagram .....	8
9	Dimension Drawing .....	8

The latest edition of these operating instructions may be downloaded from the internet as a PDF-file under [www.maxonmotor.com](http://www.maxonmotor.com), category "Service", subdirectory "Downloads", Order Number 309687.

## 1 Safety Instructions

**Skilled Personnel**

Only experienced, skilled personnel should install and start the equipment.

**Statutory regulations**

The user must ensure that the amplifier and the components belonging to it are assembled and connected according to local statutory regulations.

**Additional safety equipment**

Any electronic apparatus is, in principle, not fail-safe. Machines and apparatus must therefore be fitted with independent monitoring and safety equipment. If the equipment breaks down, if it is operated incorrectly, if the control unit breaks down or if the cables break, etc., it must be ensured that the drive or the complete apparatus is kept in a safe operating mode.

**Over-temperature**

Once the over-temperature deactivation is enabled the supply voltage cannot be limited anymore. If the Shunt regulator fails it must be guaranteed that the drive or the entire system is led into a safe operating condition.

**Repairs**

Repairs may only be carried out by authorised personnel or the manufacturer. It is dangerous for the user to open the unit or carry out any repairs.

**Danger**

Ensure that no apparatus is connected to the electrical supply during installation. After switching on, do not touch any live parts!

**Switched off status**

If the supply voltage is turned off, the capacitors used in this device are still capable of conducting voltage.

**Wiring procedure**

All cable connections should only be connected or disconnected when the power is switched off.

**Electrostatic sensitive device (ESD)**

## 2 Performance Data

### 2.1 Electrical data

Supply voltage $V_{CC}$ .....	12...50 VDC
Threshold voltage $V_{th}$ .....	27 VDC or 56 VDC
Max. continuous power loss $P_{cont}$ without additional cooling at $T_U=25^\circ\text{C}$ .....	10 W
Intermittent power loss $P_{max}$ .....	see <a href="#">Diagram 1, Chapter 6</a>
Max. current .....	5 A
No-load current .....	15 mA

### 2.2 Capacity

Capacity of the capacitors .....	940 $\mu\text{F}$
----------------------------------	-------------------

### 2.3 Inputs

Voltage Input .....	12...50 VDC
Set value of the threshold voltage .....	selectable by jumper JP1

### 2.4 Outputs

Voltage Output .....	12...50 VDC
----------------------	-------------

### 2.5 Display

LED green .....	Operating status
LED yellow .....	Shunt regulator active

### 2.6 Ambient temperature / humidity range

Operation temperature .....	see <a href="#">Diagram 2, Chapter 7</a>
Storage .....	-40...+85 $^\circ\text{C}$
No condensation .....	20...80 %

### 2.7 Mechanical data

Weight .....	approx. 60 g
Dimensions .....	see <a href="#">Dimension drawing, Chapter 9</a>
Fastening .....	Mounting plate for M3 screws

### 2.8 Connections

Removable PCB-clamps .....	4 poles
Pitch .....	3.5 mm
Suitable for wire cross section .....	0.14...1.5 $\text{m}^2$ (AWG 26-16)

### 3 Minimum External Wiring

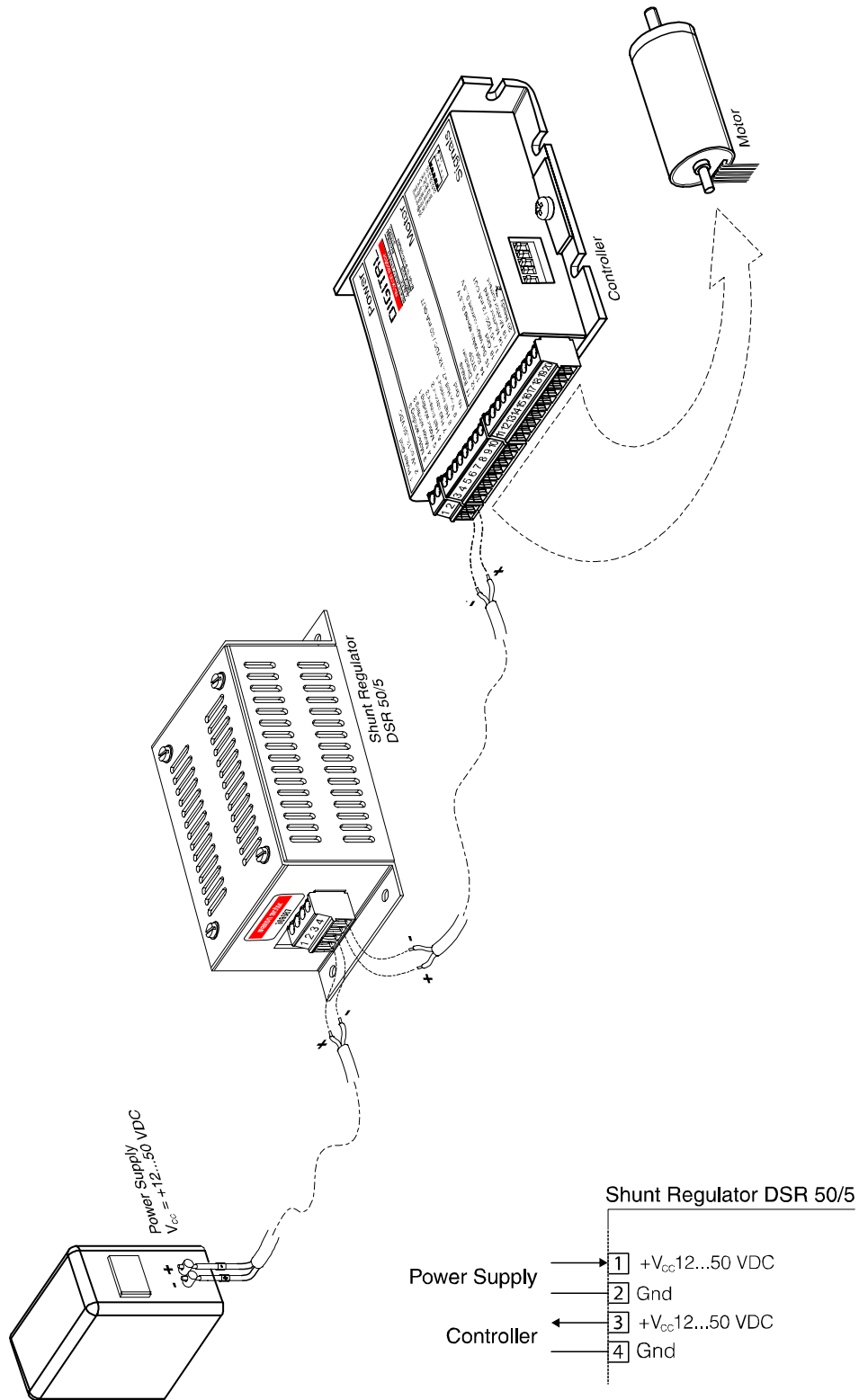

Figure 1: Minimum External Wiring



## 4 Operating Instructions

### 4.1 Power supply

The connection of the shunt regulator to the supply voltage must be parallel to the amplifier. The operating voltage of the shunt regulator and the amplifier must be set between 12 VDC to 50 VDC. Otherwise there are no further special requirements for the supply.

### 4.2 Select the threshold voltage $V_{th}$

To select the threshold voltage use **JP1**:

Jumper JP1	Threshold voltage $V_{th}$
 open	27 V
 closed	56 V

Pre-adjustment: **JP1** closed = 56 V



#### Important:

It is imperative that the following conditions are considered when adjusting the threshold voltage:

- ⇒ The selected value must be higher than the nominal voltage of the power supply unit in use.
- ⇒ The selected value has to be lower than the over-voltage threshold of the amplifier in use.

**Note:** The new threshold voltage will not be accepted until powering down / powering up the supply voltage  $V_{CC}$ .

## 5 Operating Status

### 5.1 Normal operation

The **green LED** is lit continuously.

### 5.2 Shunt Regulator active

The **yellow LED** shows if the shunt regulator is activated (electrical energy will be converted into heat).

**Note:** Check the position of the **JP1** jumper and the power supply voltage if the **yellow LED** is lit continuously.

### 5.3 Over temperature

The **green LED** blinks fast, if the temperature of the shunt regulator exceeds the maximum value.



**Important:**

- ⇒ Once the over-temperature deactivation is enabled the supply voltage cannot be limited anymore. If the shunt regulator fails it must be guaranteed that the drive or the entire system is put into a safe operating state.
- ⇒ The over-temperature deactivation will only be enabled if the shunt regulator is operated outside of the specified range!

## 6 Diagram 1: Maximal performance depending on time

The following diagram shows how long a given power value can be dissipated by the shunt regulator.

The values in the diagram are valid for a starting temperature of 25°C of the shunt regulator. The duration of power dissipation is reduced if the shunt regulator has dissipated power before applying a power pulse.

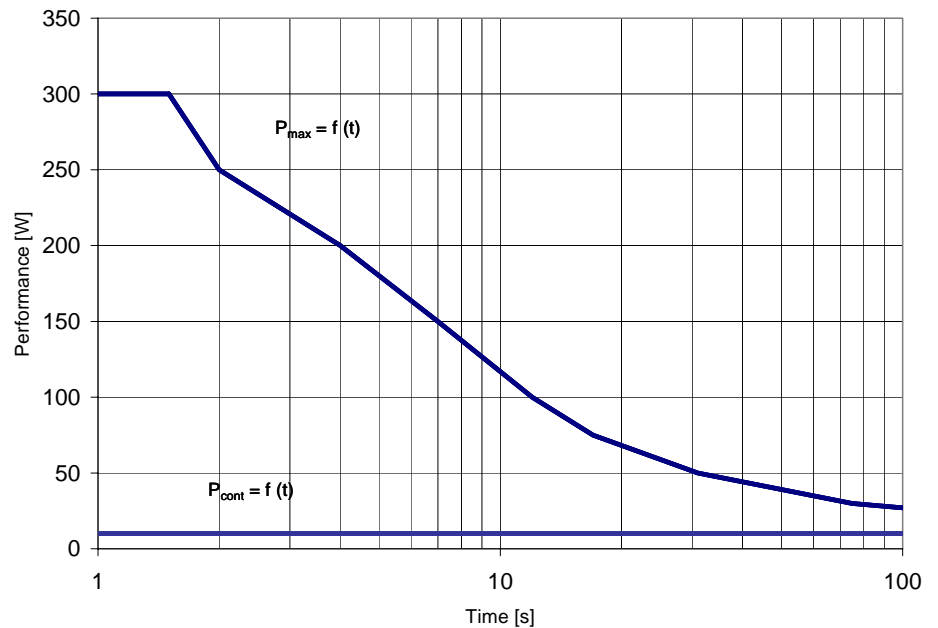

Diagram 1: Maximal performance depending on time

## 7 Diagram 2: Maximal power dissipation depending on temperature

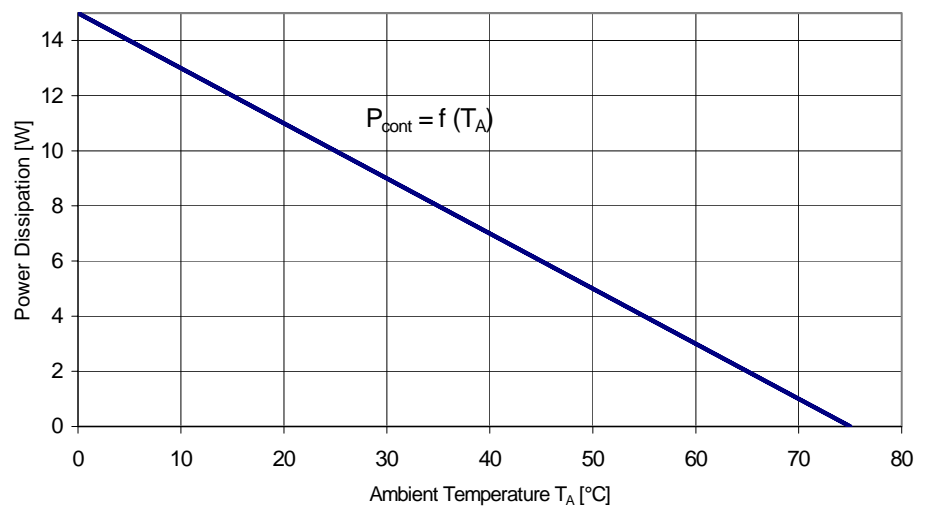

Diagram 2: Maximal Power Dissipation depending on temperature

## 8 Block Diagram

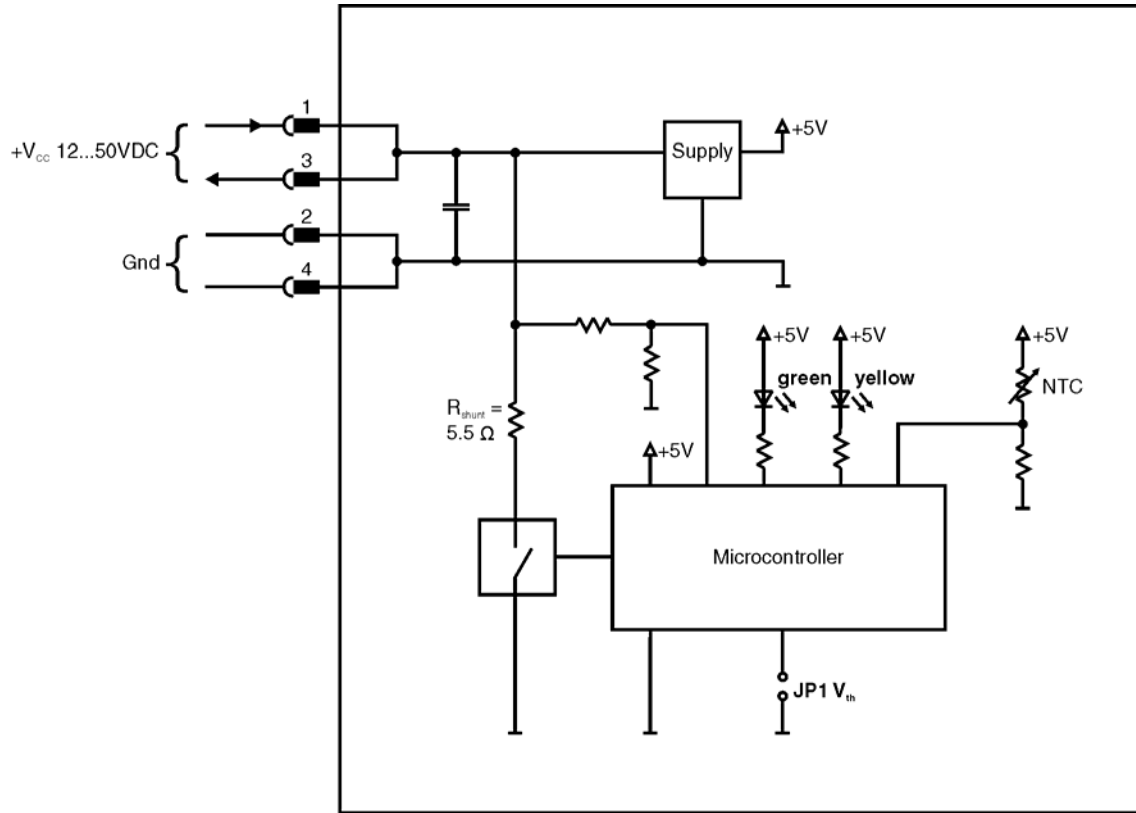

Figure 2: Block Diagramm

## 9 Dimension Drawing

Dimensions in [mm]

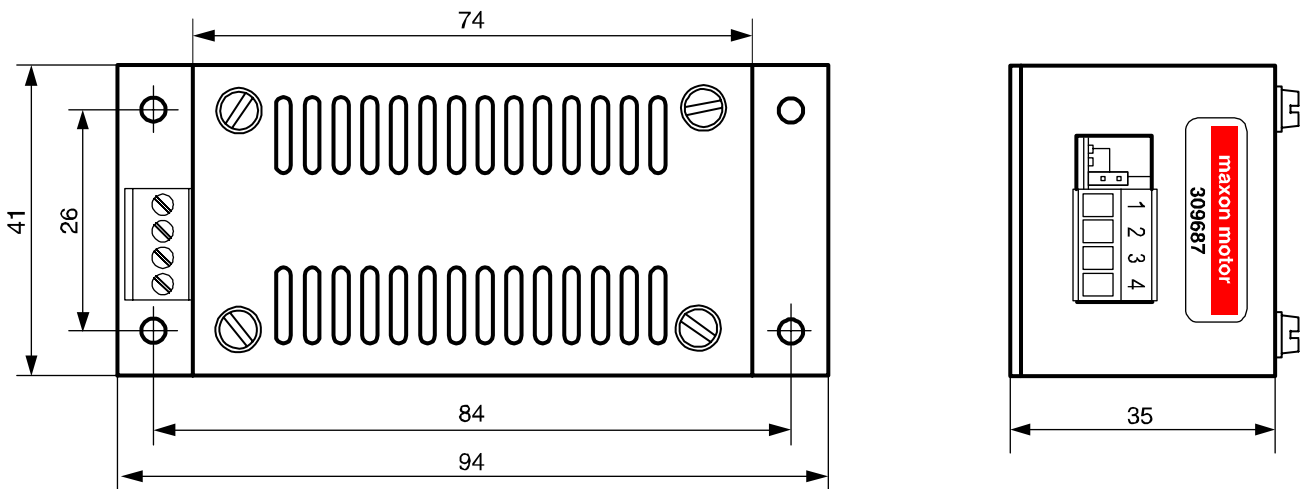

Figure 3: Dimension drawing